

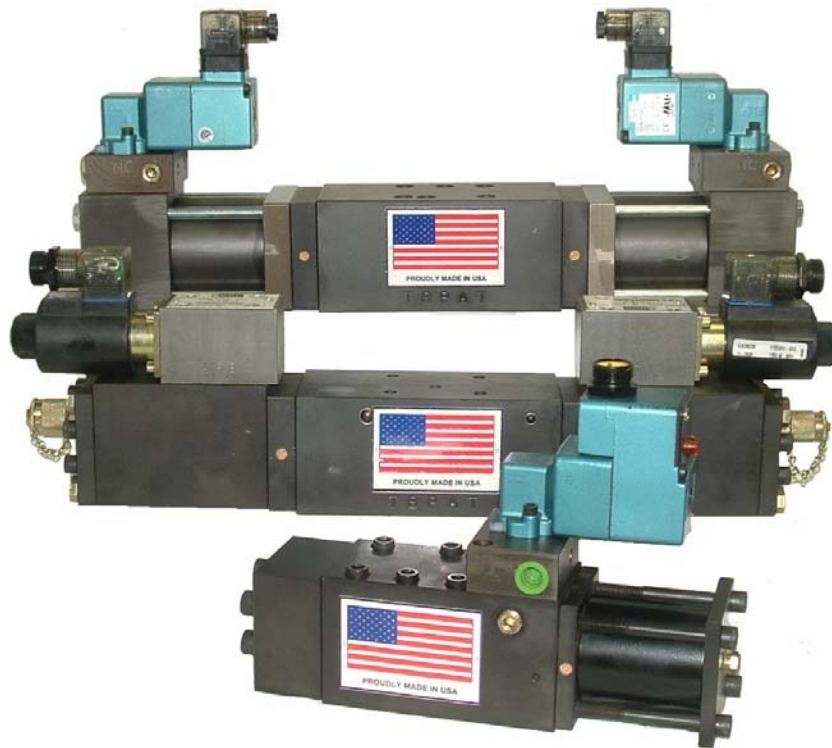

Water Hydraulics, Inc.

High Pressure Water - *Directional Control Valve* - *V010 Series*



Packed Spool Type
Zero Leakage
Raw Water Operation
Up to 5000 psi



Proudly Made in USA

BOC Water Hydraulics Inc.
12024 Salem Warren Road
P.O. Box 1028
Salem, Ohio 44460

Visit Us on the Web At:
www.bocwaterhydraulics.com

Overview

BOC's V010 line of high pressure water packed spool type directional control valves are designed specifically for mill duty applications. Whether acting as a stand alone directional valve or functioning as a pilot valve on a valve arrangement, the V010 valve provides reliable performance in harsh fluid environments. Rated fluid environments include raw contaminated water (such as descale water), low viscous fluids (such as 95/5 and Norpar), and high viscous oils.

The valve line is highly flexible. Three different actuator actions, including air operated, hydraulically operated, and lever operated are supported. Each mode of actuation provides assured shifting forces for flawless and reliable repetitive shifting. Several valve actions are available to support most standard and even many unique hydraulic applications. Additional configurations are available upon request.

Valves are designed to bolt to a standard D05 interface. However, given the high pressure nature of many of BOC's applications, mounting pad interface design has been strengthened by upsizing mounting bolts and adding additional hold down bolts. (See pages 4 and 5 for additional details.)

V010 valves are constructed with the highest quality materials and machining techniques to lengthen valve life and performance while minimizing downtime and maintenance. All main valve internal parts are constructed out of 17-4 ph stainless steel. Plungers are specifically designed to provide smooth shifting characteristics and to reduce decompression shock. Housings and end caps are protected with *Ollinite™* to resist corrosion and wear. Furthermore, valve design is modular. Actuators can be removed independently from main valve for service.

The valve contains several additional features to facilitate maintenance and extended life. Main valve cartridges are easily removed and replaced. No special tools or chemicals (such as liquid nitrogen) are required for dis-assembly and re-assembly. Internal parts such as sleeves and seals are common across valve actions – 3 way and 4 way, F04 through F19. Plunger design varies with flow actions. Key features are highlighted below.

V010 Series Main Valve (4 Way – No Actuators)

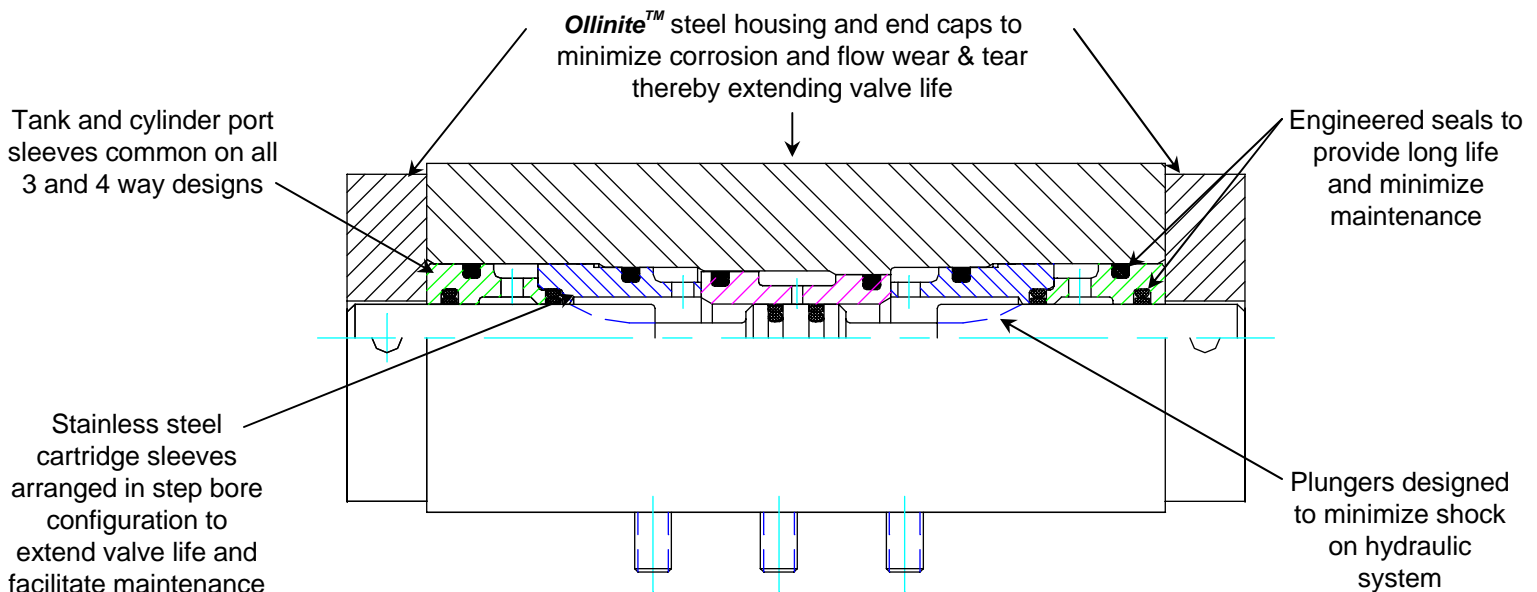

Typical Cross Section

4 Way Valve Dimensional Envelopes

Air Solenoid Operated

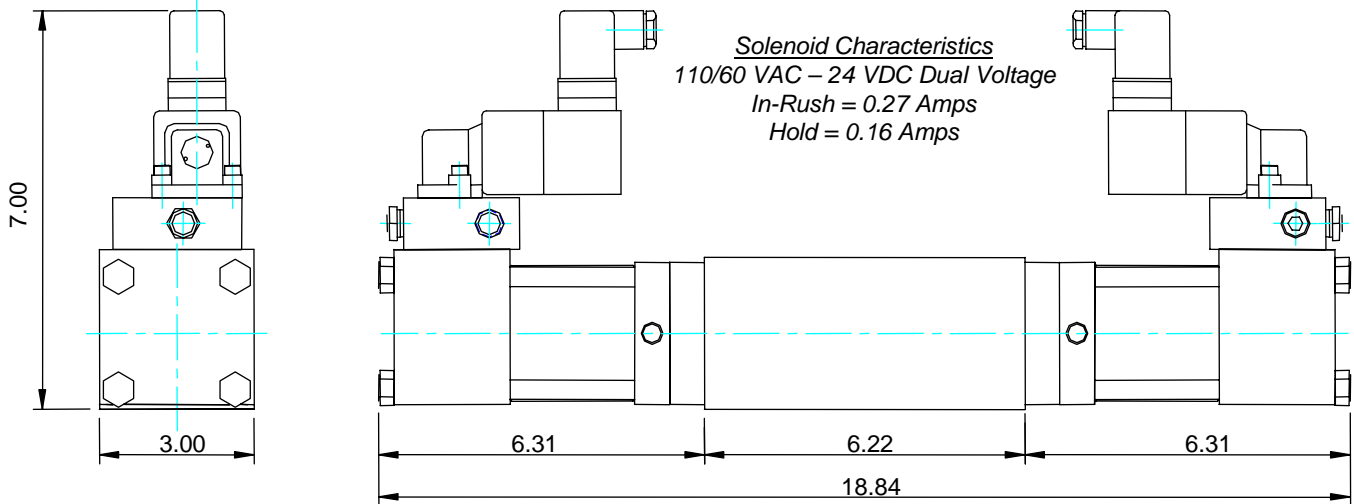

Hydraulic Solenoid Operated

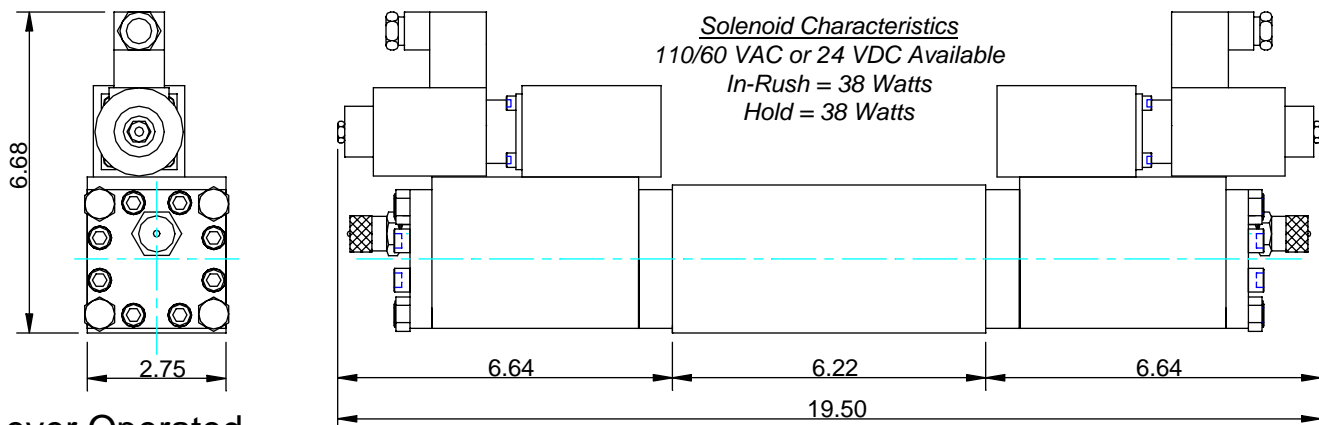

Lever Operated

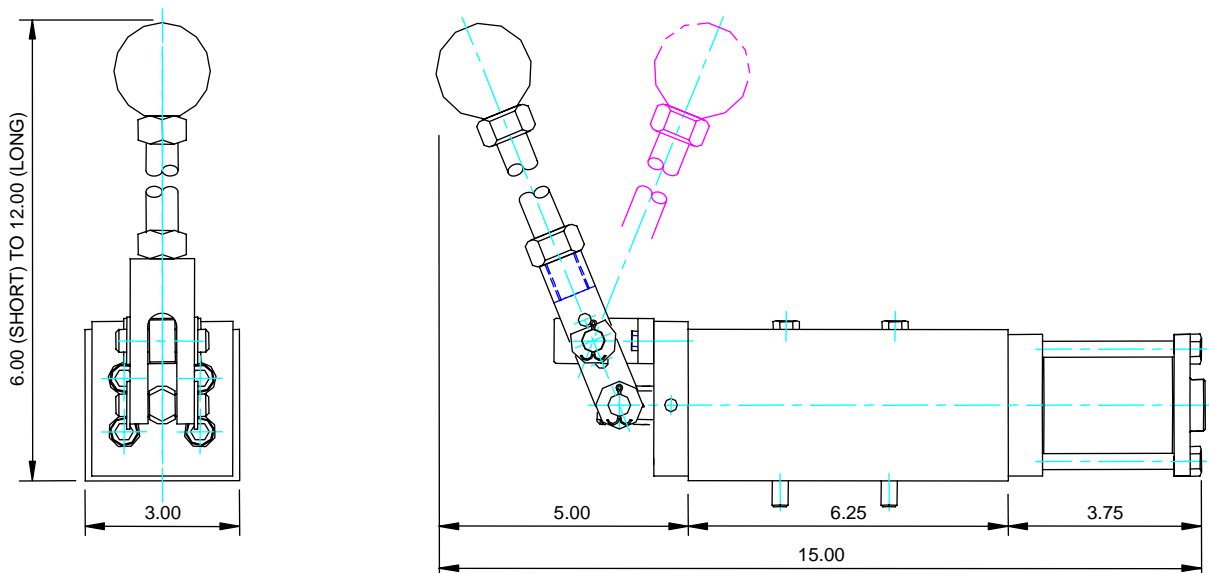

All dimensions in inches

4 Way Valve Mounting Pad

BOC's V010 Series 4 Way valves also use a variation of the NFPA D05 / ISO 4401-05 standard interface footprint.

Port spacing and size conforms to published standards. In applications requiring restricted flow, such as decompression, port diameters may be undersized (less than .44" Dia.) and tapped for installation of a fixed orifice in any of the three ports. Typically, 1/4"-20 UNC or 5/16" – 18 UNC taps are used in such situations.

Mounting bolt spacing conforms to published standards. BOC adds two additional mounting holes to increase valve hold-down force in high pressure applications. The two holes near center-line are additional. Furthermore, BOC increases tapped hole size from the 'standard' 1/4"-20 UNC to 5/16" – 18 UNC. Again, this creates additional holding force for higher pressure applications.

Valves conforming to the NFPA D05 / ISO 4401-05 standard interface (with 1/4"-20 UNC mounting bolts) are available and carry the optional feature designation of /D05 (See ordering information key).

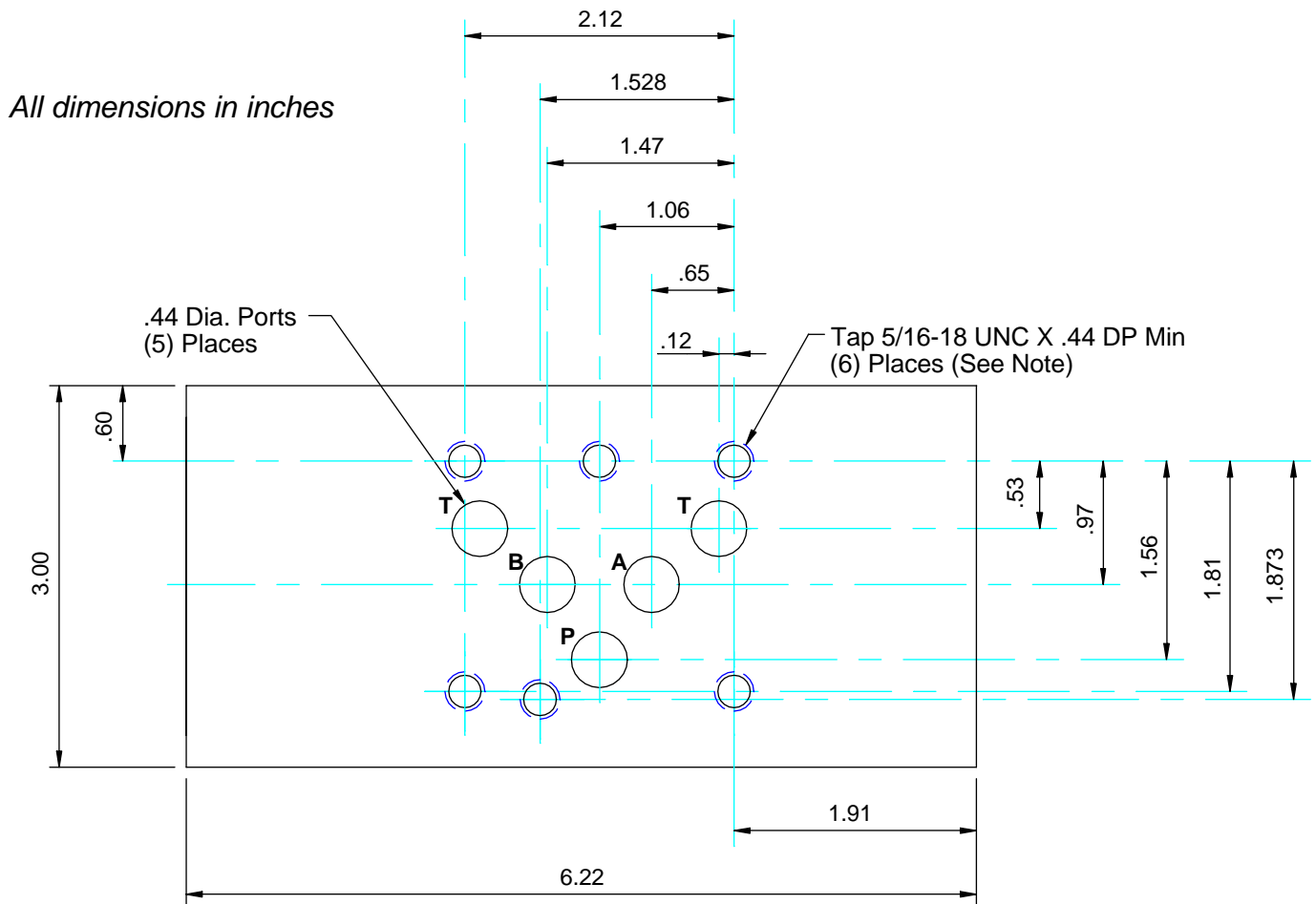

3 Way Valve Mounting Pad

BOC's V010 Series 3 Way valves use a variation of the NFPA D05 / ISO 4401-05 standard interface footprint.

Port spacing and size conforms to published standards. However, only the "B" cylinder port and one of the "T" tanks ports are used in addition to the "P" port. In applications requiring restricted flow, such as decompression, port diameters may be undersized (less than .44" Dia.) and tapped for installation of a fixed orifice in any of the three ports. Typically, 1/4"-20 UNC or 5/16" – 18 UNC taps are used in such situations.

Mounting bolt spacing conforms to published standards. BOC adds two additional mounting holes to increase valve hold-down force in high pressure applications. The two holes near center-line are additional. Furthermore, BOC increases tapped hole size from the 'standard' 1/4"-20 UNC to 5/16" – 18 UNC. Again, this creates additional holding force for higher pressure applications.

Pneumatic operated three way valves offer an internal feed path for solenoid air as shown below. Mounting pad size is adjusted accordingly to account for this additional port when required.

Valves conforming to the NFPA D05 / ISO 4401-05 standard interface (with 1/4"-20 UNC mounting bolts) are available and carry the optional feature designation of /D05 (See ordering information key).

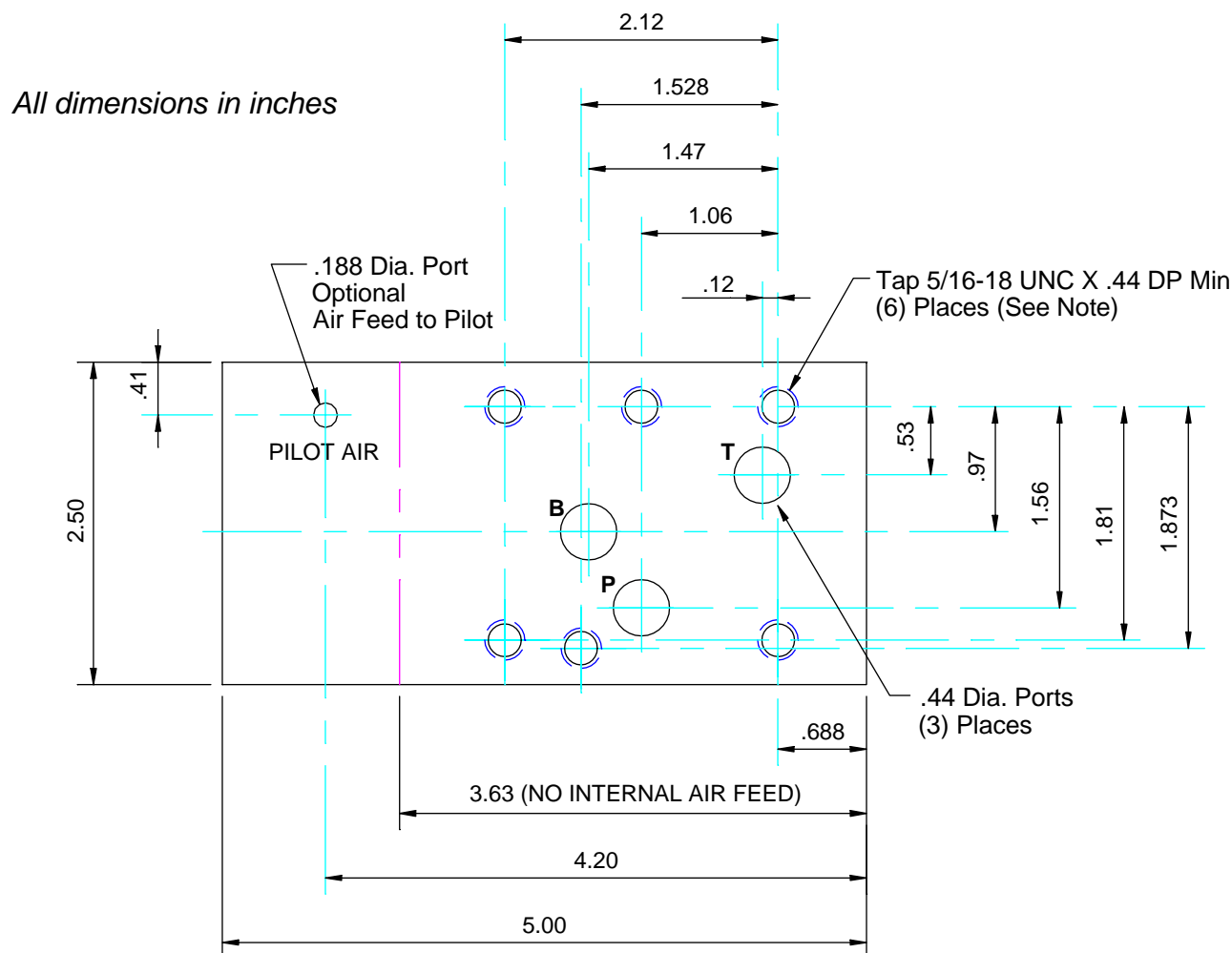

3 Way Valve Dimensional Envelopes

Normally Open (F04) Air Solenoid Operated

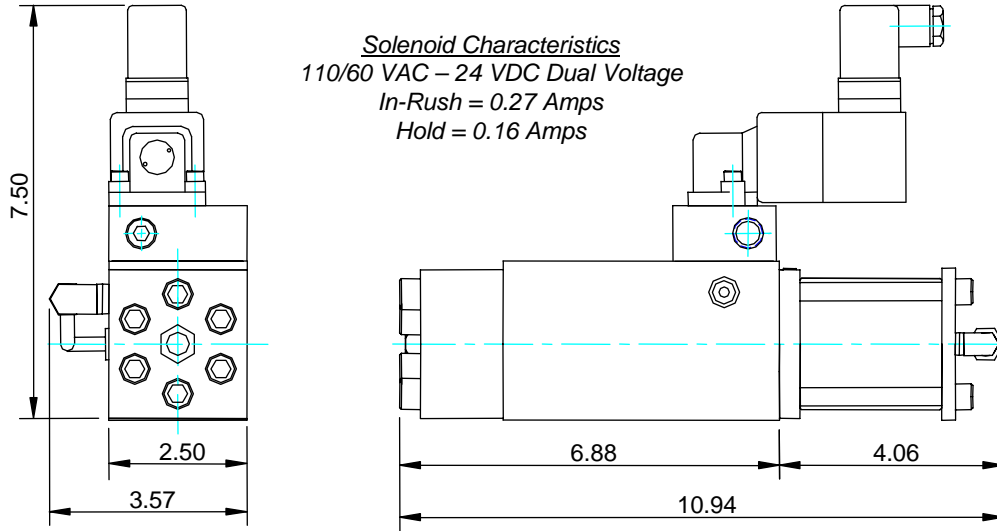

Normally Closed (F05) Air Solenoid Operated

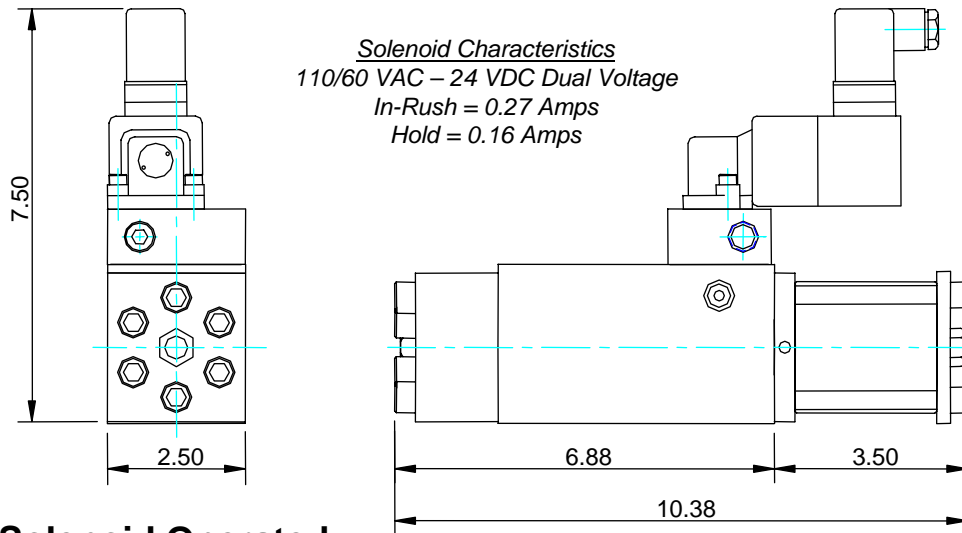

Hydraulic Solenoid Operated

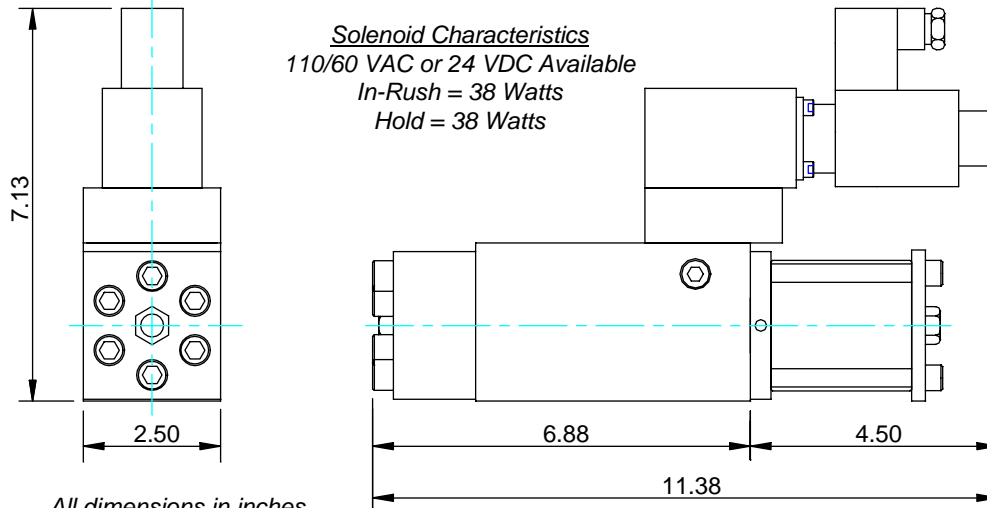

Standard Flow Patterns

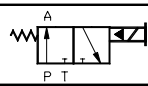
3 Way Valves		
2 Positions		
Flow No.	Description	Typical Schematic *
F04	Normally Open	
	Normally Closed	

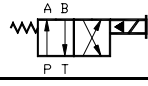
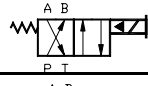
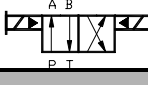
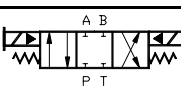
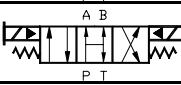
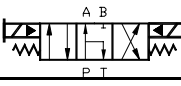
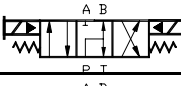
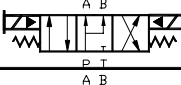
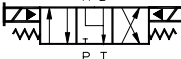
4 Way Valves		
2 Positions		
Flow No.	Description	Typical Schematic *
F11	P to A	
	B to T	
F12	P To B	
	A to T	
F13	Double Solenoid	
	Double Solenoid	
3 Positions		
Flow No.	Description	Typical Schematic *
F14	Blocked Center	
	Center	
F15	Open Center	
	Center	
F16	P to T Thru A	
	B Blocked	
F17	P to T Thru B	
	A Blocked	
F18	Compound Supply	
	Compound Supply	
F19	Compound Exhaust	
	Compound Exhaust	

* Hydraulically operated schematics shown.
Schematics vary as actuators change.

Ordering Information

V 010 - 01 - 43 - F18 / JP / HH - 048

VALVE ASSEMBLY

VALVE SIZE	
010	10 GPM Cv = 1.5

VALVE ACTUATOR	
01	Air Solenoid
02	Hydraulic Solenoid
03	Lever Operated
04	Remote Air Operated
05	Remote Hydraulic Operated

VALVE ACTION CATEGORY		
32	3 Way	2 Position
42	4 Way	2 Position
43	4 Way	3 Position

SEQUENCE NUMBER	
XXX	3 Digit Unique Identifier for specific Bill of Material
* Not Required When Ordering	

SPECIAL FEATURES	
D05	NFPA D05 (1/4"-10 UNC Mtg Bolts)
BH	Brad Harrison Electrical Connector
JP	Joy Plug Electrical Connector
HH	Hex Head Mounting Bolts
V	Viton Seals
IA	Internal Air Supply (3 Way Only)
CRN	TSSA Certified (Canada)
XXX	Solenoid Voltage (Other than 120 VAC)

DETAILED FLOW CONFIGURATION	
F04	3 Way, 2 Position, Normally Open
F05	3 Way, 2 Position, Normally Closed
F06	3 Way, 2 Position, Double Solenoid
F07	3 Way, 3 Position, Blocked Center
<i>And So Forth ...</i>	
* See flow pattern table. Other flow patterns available.	

Factory Assistance - Call

Phone: 330-332-4444

Fax: 330-332-1650